

Technical Data Sheet

CODE 17144

LINEO 100

Mixed flow extractor fans



Certifications



IMQ Performance



UKCA

TECHNICAL AND PERFORMANCE DATA

Absorbed power 1st speed (W)	20	Delivery 1st speed (l/s)	50
Frequency (Hz)	50	Delivery 1st speed (m ³ /h)	180
Insulation Class	II°	Max delivery at max speed (l/s)	70,8
IP	44	Max delivery at max speed (m ³ /h)	255
Max ambient temperature for continuous operation (°C)	60	Pressure - 1st speed (mmH2O)	13
Max. absorbed Current at max. speed (A)	0,11	Pressure - 1st speed (Pa)	127,5
Max. absorbed Current at min. speed (A)	0,09	Pressure max - max speed (mmH2O)	16,5
Max. absorbed power at max speed (W)	23	Pressure max - max speed (Pa)	161,9
Nominal Diameter (mm)	100	RPM max	2030
Voltage (V)	220-240	RPM min	1520
Weight (Kg)	2	Sound pressure level Lp [dB (A)] 3m - max speed	39,4
		Sound pressure level Lp [dB (A)] 3m - min speed	30,7

DIMENSIONS

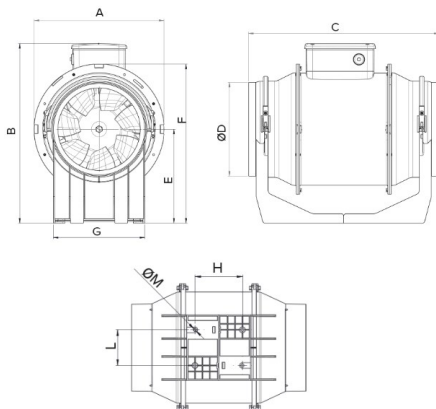

Size A (mm)	188,5
Size B (mm)	211
Size C (mm)	303
Size D (mm)	96
Size E (mm)	101,5
Size F (mm)	189
Size G (mm)	90
Size H (mm)	60
Size L (mm)	80
Size M (mm)	5,5

PER INFORMAZIONI:

Servizio al Cliente: tel +39 02 90699395 premendo 1 dopo messaggio registrato (consulenza su prodotti e impianti)

Pre & Post Vendita: fax +39 02 90699302

Email prevendita: prevendita@vortice-italy.com

Technical Data Sheet

CODE 17144

LINEO 100

Mixed flow extractor fans



DESCRIPTION

- Enclosures made of fire resistant plastic resin, E2 class, according with ISO EN 11925-2: 2010, in areas close to motor and electrical components.
- Nominal diameter 100 mm.
- Induction motor, thermally protected, with shaft mounted on ball

- bearing supports, coupled with a centrifugal impeller.
- High water resistance: IPX5 (if installed in a duct).
- Speed adjustable through Vortice speed devices.

CURVES

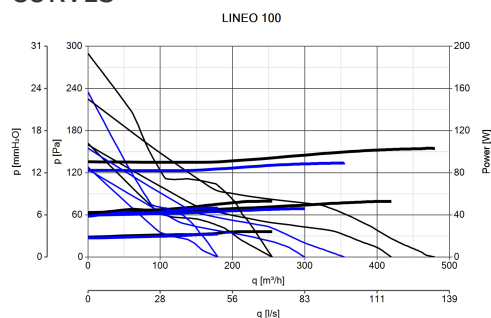

ACCESSORIES



C PIR

Code 12998



C TEMP

Code 12992



C SMOKE

Code 12993



C HCS

Code 12994



C TIMER

Code 12999



DUO

Code 22914



LINEO-G 100

Code 22701



LINEO-PF 100

Code 22577



IN-LINE-S 100

Code 22551



LINEO-C 100

Code 22584



C 1.5 (COMANDO EL.)

le 12966

PER INFORMAZIONI:

Servizio al Cliente: tel +39 02 90699395 premendo 1 dopo messaggio registrato (consulenza su prodotti e impianti) **A)**

Pre & Post Vendita: fax +39 02 90699302

Email prevendita: prevendita@vortice-italy.com



KIT SCB
(TRASF.E.C.)

Code 22481